

# EDFA-PA-MSA



## DEVICE

## MSA Pre-Amp EDFA Module, C-band

## OVERVIEW

The Optilab EDFA-PA-MSA is a high-gain pre-amplifier module in a multiple source agreement footprint housing. It is an easy-to-use and cost-efficient solution for photonic subsystems, OEM integration, and fiber optic system integration. Using a high gain design, this pre-amp module provides over 30 dB gain with a 4.5 dB noise figure, good for input power level as low as -40 dBm. Software control via an a standard TTL RS-232 interface is available for status monitoring and pump current adjustments. It also features pump laser protection and alarms to ensure the reliability and safety of the device. The EDFA-PA-MSA only requires a single +5 Volt DC power supply for operation. Contact Optilab for more information.

## FEATURES

- MSA footprint
- RS-232 standard for remote control
- Wide wavelength operation range
- 30 dB gain
- Low noise figure
- Designed for low input level
- Single +5V power supply
- 10+ years of operation life

## USE IN

- Photonic subsystems
- Fiber optic link amplification
- OEM integration for
  - DWDM networks
  - DFC/CATV
  - RFoG/PON

## FUNCTIONAL DIAGRAM

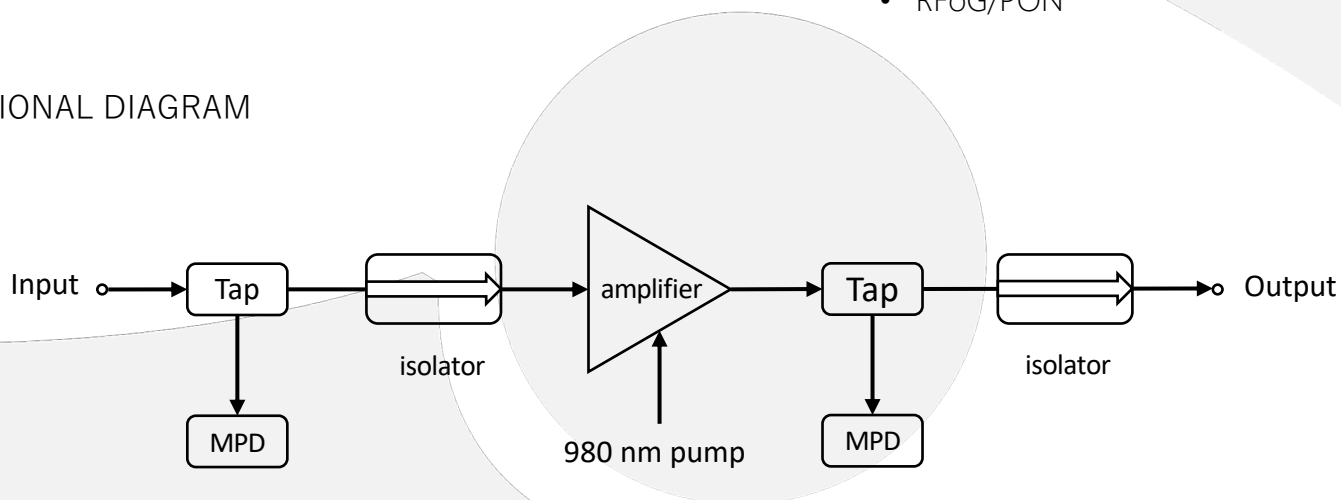

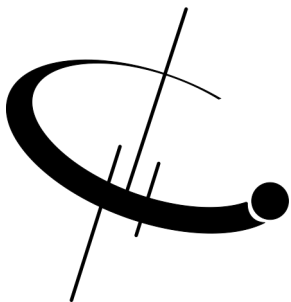

# EDFA-PA-MSA

## SPECIFICATIONS

### GENERAL

Operating Range	1528 nm – 1563 nm
Saturation Output Power	+15 dBm min. +16 dBm typical
Optical Gain	28 dB min. @ -30 dBm input
Noise Figure	4.5 dB typ., 5.0 dB max.
Optical Return Loss	50 dB min.
Input Optical Isolation	30 dB min.
Output Optical Isolation	30 dB min.
Polarization Mode Dispersion	0.1 ps max.
Polarization Dependent Gain	0.1 dB max.
Input Power Range	-40 dBm to +5 dBm
Output Power Stability	0.15 dB over 8 hours
Operation Mode	ACC
Input/Output Fiber Type	Corning SMF-28

### MECHANICAL

Operating Temperature	-10°C to +50°C
Power Supply	+5 V DC, 4.0 A max.
Power Consumption	20 W max.
Fiber Type	SMF-28
Fiber Jacket	900 um loose tube
Connector Type	FC/APC
Connector (Power and Control)	2 x 15 pin header, 1.0 mm pitch
Remote Control	RS-232 for laser control, status monitoring
Dimensions	90 mm x 70 mm x 20 mm
Power Adapters	30 Pin to Molex and USB Adapter, included
Matching Power Supply	Optilab PS-5-M, optional accessory



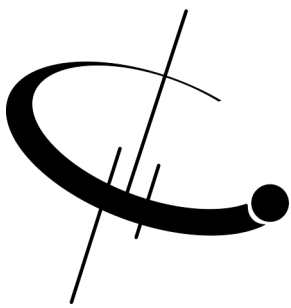

# EDFA-PA-MSA

MECHANICAL DRAWING

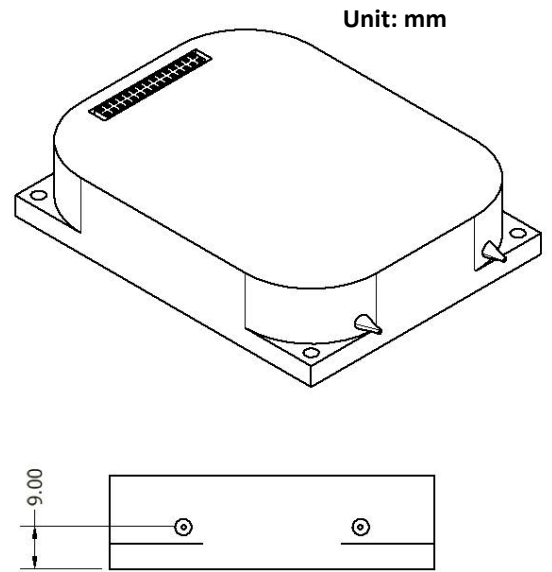
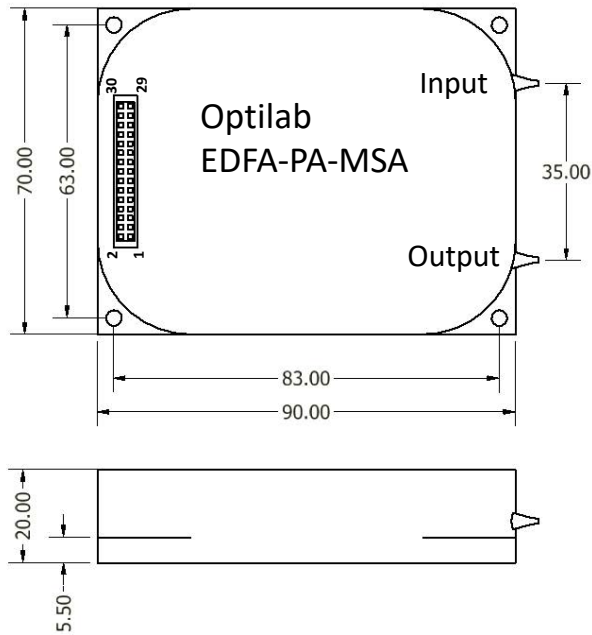

ELECTRICAL PINOUT

PIN #	DESCRIPTION	PIN #	DESCRIPTION
1	+5V	2	+5V
3	NC	4	NC
5	GND	6	GND
7	RS232 RX, TTL	8	RS-232 TX, TTL
9	GND	10	GND
11	NC	12	NC
13	Amplifier Enable, active low, 3.3V LVCMOS	14	NC
15	Case Temp Alarm*, active high, 3.3V LVCOMS	16	NC
17	NC	18	NC
19	Loss of Input Alarm*, active high, 3.3V LVCMOS	20	Loss of Output Alarm*, active high, 3.3V LVCOMS
21	GND	22	GND
23	NC	24	NC
25	GND	26	GND
27	NC	28	NC
29	+5V	30	+5V

\* Alarm function is disabled in the firmware.



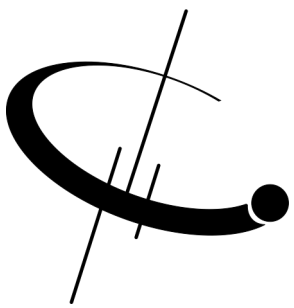

# EDFA-PA-MSA

## GAIN SPECTRUM

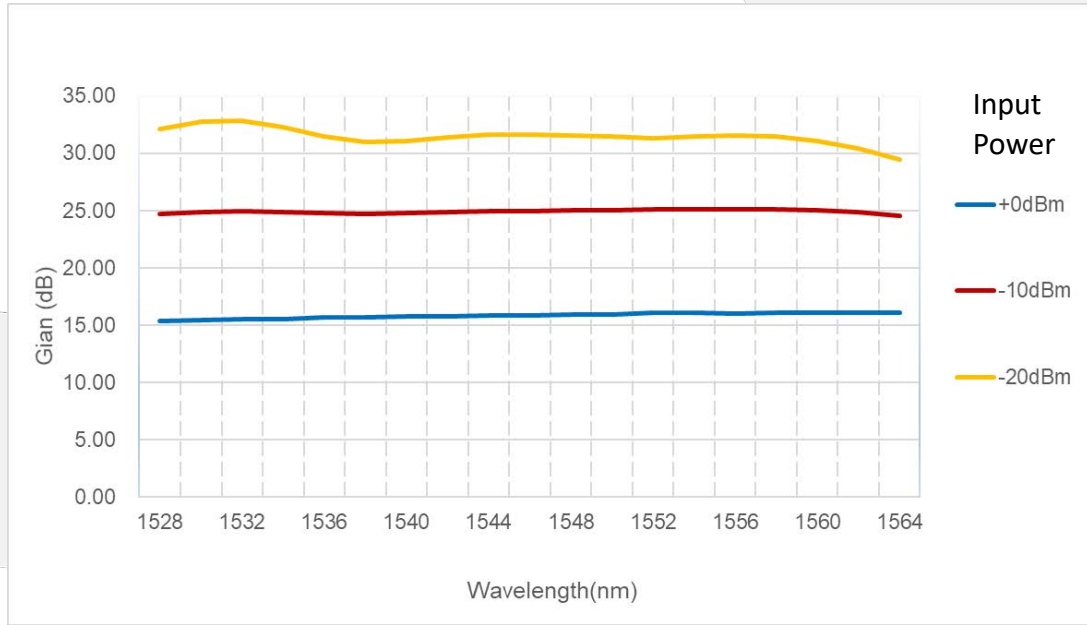

## ACCESSORIES

