

Ampheia™ Series

Ultra-Low Noise | Single Frequency | Fiber Amplifier



Applications

- Quantum Sensing
- Atom Trapping and Cooling
- Particle Analysis
- Optical Metrology
- Semiconductor Inspection
- Holography
- Low-Noise Laser Pump Source

Features

- Up to 50 W at 1064 nm and up to 5 W at 532nm, CW, single-frequency emission
- Ultra-low relative intensity noise and perfect beam quality
- Single-stage fiber amplifier with integrated seed laser
- Optical signal to noise ratio (OSNR > 80 dB)
- Robust and maintenance free

The Ampheia™ Series is a family of high-power fiber amplifiers, which with a pinnacle of perfection boosting ultra-low relative intensity noise (RIN) and single-frequency operation while delivering 20 W, 40 W, and 50 W at 1064 nm and 5 W at 532 nm in a perfect beam.

Ampheia™ Series is a single-stage fiber amplifier built around an internal seed laser and presents affordable, outstanding laser performance tailored for quantum applications. Offered in a 19 inch 3U rack case, this amplifier offers excellent robustness.

With single-frequency precision, the fiber amplifier offers a long coherence length. Thoroughly designed and manufactured, Ampheia™ Series of fiber amplifiers guarantee a high level of reliability, making them ideal for stand-alone use or seamless integration as an OEM component. It caters to a spectrum of applications ranging from atomic trapping, optical metrology, particle analysis, semiconductor inspection to quantum applications.

Typical Relative Intensity Noise (RIN)

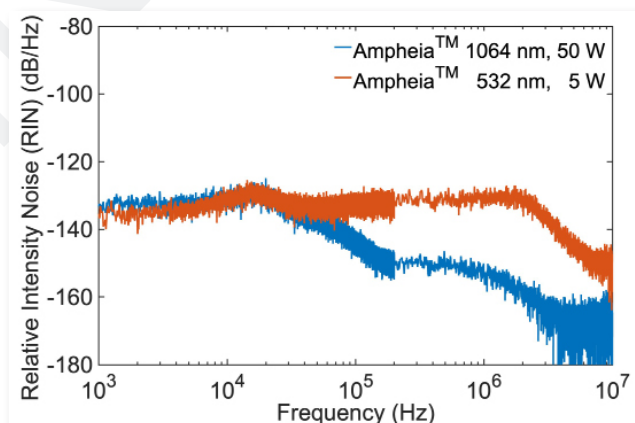

Typical TEM₀₀ Beam Profile

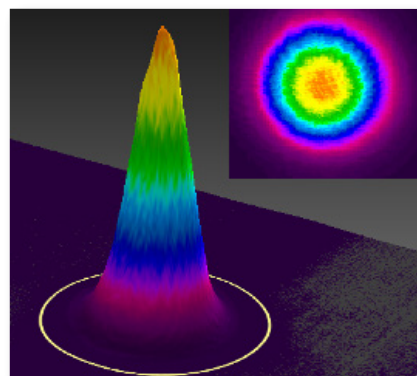

HÜBNER Photonics



Ampheia™ Series

Optical Specifications

Ampheia™				
Wavelength	1064.2 ± 0.6 nm			532.2 ± 0.6 nm
Output power (after integrated isolator ¹)	20 W	40 W	50 W	5 W
Operation mode	Continuous wave			
Spectral linewidth (FWHM, 1 ms)	< 50 kHz			< 100 kHz
Coherence length	> 1 km			
Polarization extinction ratio (PER) [dB] (Vertically polarized)	> 1000:1 [> 30 dB]			
Spatial mode	TEM ₀₀ (M ² < 1.05)			
Nominal beam diameter at aperture	1 ± 0.2 mm			
Noise [100 Hz- 10 MHz]	< 0.05 % RMS			< 0.08 % RMS
Relative intensity noise (RIN)	10 Hz- 1 kHz	< - 110 dB/Hz		< - 100 dB/Hz
	1 kHz - 100 kHz	< - 135 dB/Hz		< - 125 dB/Hz
	100 kHz - 1 MHz	< - 150 dB/Hz		< - 130 dB/Hz
Optical signal to noise ratio (OSNR)	> 80 dB			
Output power tunability	5 % to 100 %	2.5 % to 100 %	2 % to 100 %	0 % to 100 %
Fiber delivery cable length	1.5 m	1.2 m	1.0 m	1.5 m

¹ Only for 1064 nm

Electrical/Meachanical/Operational Enviromental Specifications

Ampheia™		
Wavelength	1064 nm	532 nm
Fiber amplifier rack weight	17.66 kg (38.93 lbs.)	18.6 kg (41 lbs.)
Fiber amplifier rack dimensions (LxWxH)	470.5x423x133 mm (18.52x16.65x5.24 in.)	
Laser head weight	0.76 kg (1.68 lbs.)	0.62 kg (1.37 lbs.)
Laser head dimensions (LxWxH)	155x55x45 mm (6.10x2.17x0.87 in.)	
Intended use environment	Laboratory (indoor)	
Ambient temperature, operation	18 - 30 °C (Air-cooled)	
Ambient temperature, storage	-10 to +60 °C	
Humidity	0 - 60 % RH non-condensing	
Laser head heat sink thermal impedance (at 30°C ambient)	< 2 K/W	
System power consumption	< 300 W	
Maximum heat dissipation of laser head	< 2 W ¹	

¹ Only with open shutter.

Model Number

A1-WWWW-1010F-PPPP-2000

↑ ↑ ↑
Wavelength Power Configuration:

1000 = CE Compliant, standard
1xxx = CE Compliant, custom
2000 = OEM, standard
2xxx = OEM, custom



WARNING
VISIBLE OR INVISIBLE
LASER RADIATION
Avoid Exposure to beam
Class 4 Laser Product
Classified per
IEC 60825-1:2014



Wvl (nm)	Max.Pwr (W)
1064	50
532	5



This device is
sensitive to
Electrostatic
Discharge
(ESD).

Communication Interface

Communication	USB or RS-232
Standard Baudrate	115200

Specifications and technical data are subjects to change without notice due to technical developments.

Ampheia™ Series

Mechanical Specifications

Fiber Amplifier Rack dimensions: Ampheia™ 1064 nm

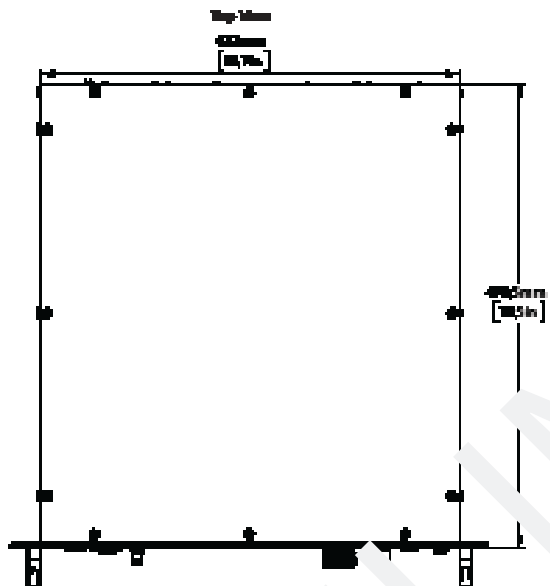
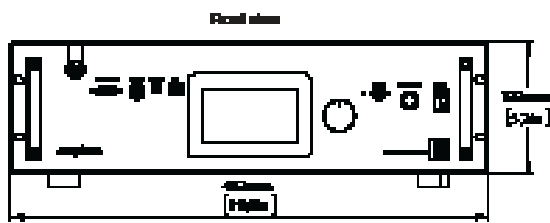

Fiber Amplifier Rack dimensions: Ampheia™ 532 nm

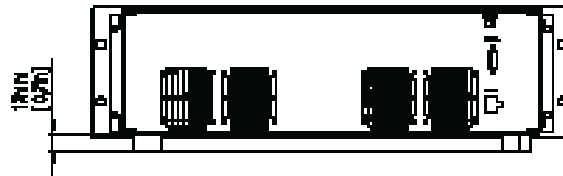
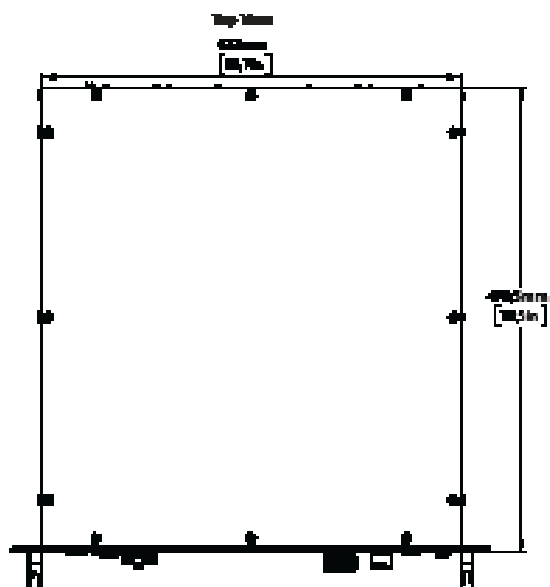
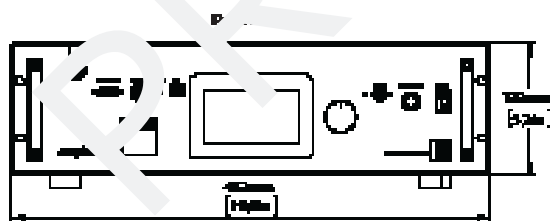

Ampheia™ Series

Mechanical Specifications

Laser head dimensions: Ampheia™ 1064 nm

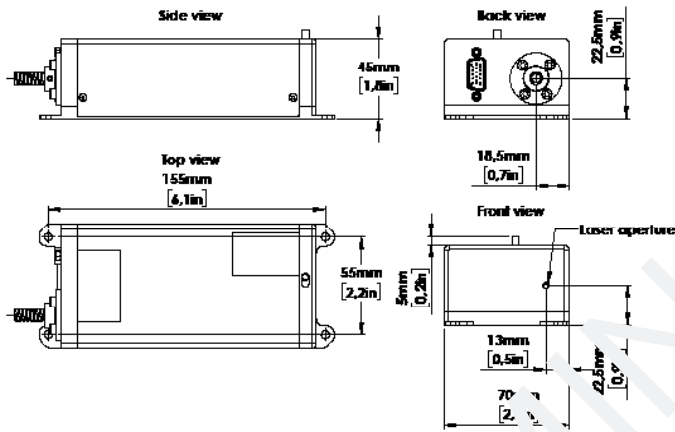

Laser head dimensions: Ampheia™ 532 nm

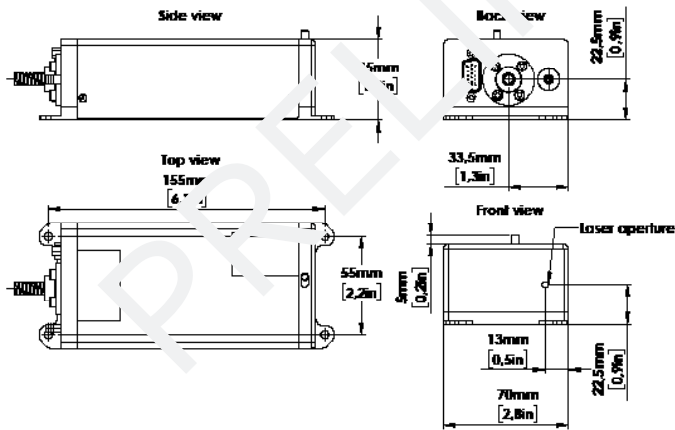

Our Locations

Cobolt AB, a part of HÜBNER Photonics
(Sales in Norway, Sweden, Finland and Denmark)
Solna, Sweden
Phone: +46 8 545 912 30
Fax: +46 8 545 912 31
E-mail: info@hubner-photonics.com

HÜBNER Photonics GmbH
(Sales in Germany, Switzerland and Austria)
Kassel, Germany
Phone: +49 561 994 060-0
Fax: +49 561 994 060-13
E-mail: info.de@hubner-photonics.com

HÜBNER Photonics Inc.
(Sales in USA, Canada and Mexico)
San Jose, California, USA
Phone: +1 (408) 708 4351
Fax: +1 (408) 490 2774
E-mail: info.usa@hubner-photonics.com

HA Photonics Pty Ltd
(Sales in UK and Ireland)
London
United Kingdom
Phone: +44 7359 440 871
E-mail: info.uk@hubner-photonics.com

VALO Innovations, a part of HÜBNER Photonics
(VALO Sales and Service)
Hannover, Germany
Phone: +49 511 260 390 70
E-mail: info.valo@hubner-photonics.com

Find local sales representatives at hubner-photonics.com

